

Mission Critical Metallica[®]

Titanium Demand and Trends in the Jet Engine Market

Hunter Dalton, EVP ATI High Performance Specialty Materials Group

May 20, 2014













© 2014 ATI. All Rights Reserved.



Forward Looking Statements

This presentation contains forward-looking statements. Actual results may differ materially from results anticipated in the forward-looking statements. These and additional risk factors are described from time to time in the Company's filings with the Securities and Exchange Commission, including its Annual Report on Form 10-K for the year ended December 31, 2013.

Commercial Aerospace Market Drivers

	Change	Specialty Metals Market Impact
Traffic (RPMs)		
Capacity (ASMs)		
Airline Profitability		
Fuel Costs		
International Carriers		
Growth of Low-Cost Carriers		

(Sources: Airline Monitor, IATA press releases)

(Sources: Airline Monitor, IATA press releases)

Air Transport Production Market

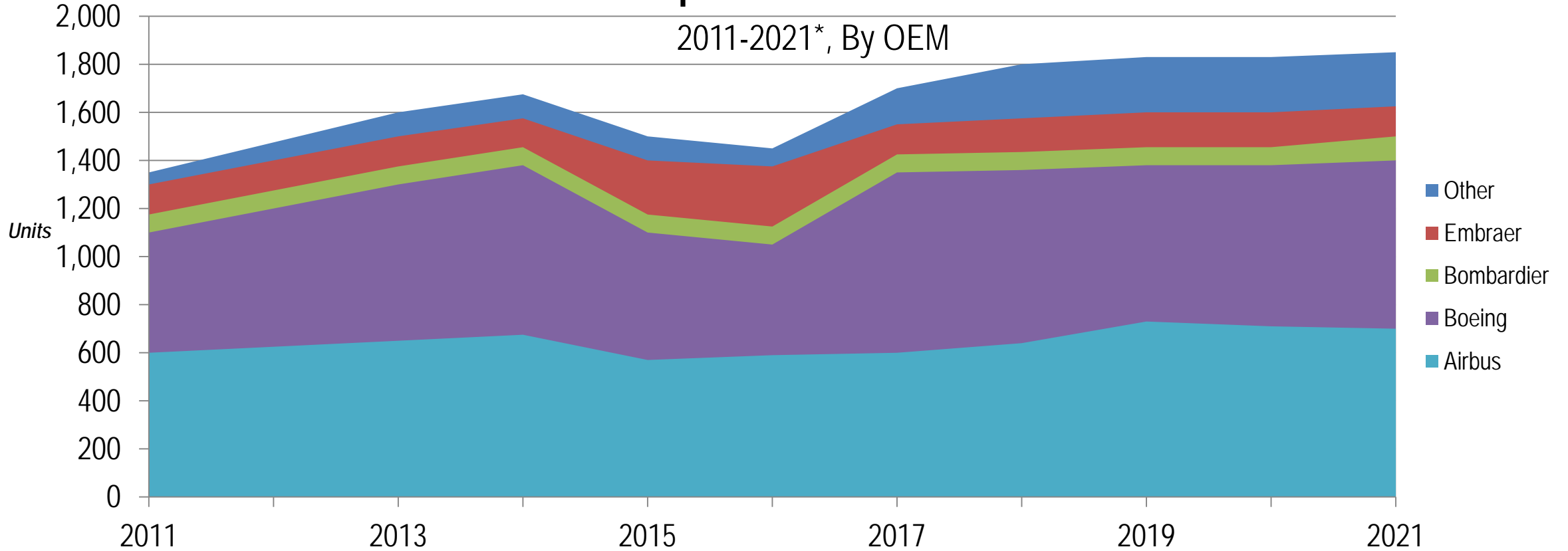

*Drop in forecasted production rates from 2014 to 2016 is due to potential change in orders, shifting from legacy aircraft to the next generation single aisle.

Secular Growth Trends
Titanium intensive airplanes
Fuel efficient hotter burning engines

Aeroengine Production Market

2011-2021, By OEM

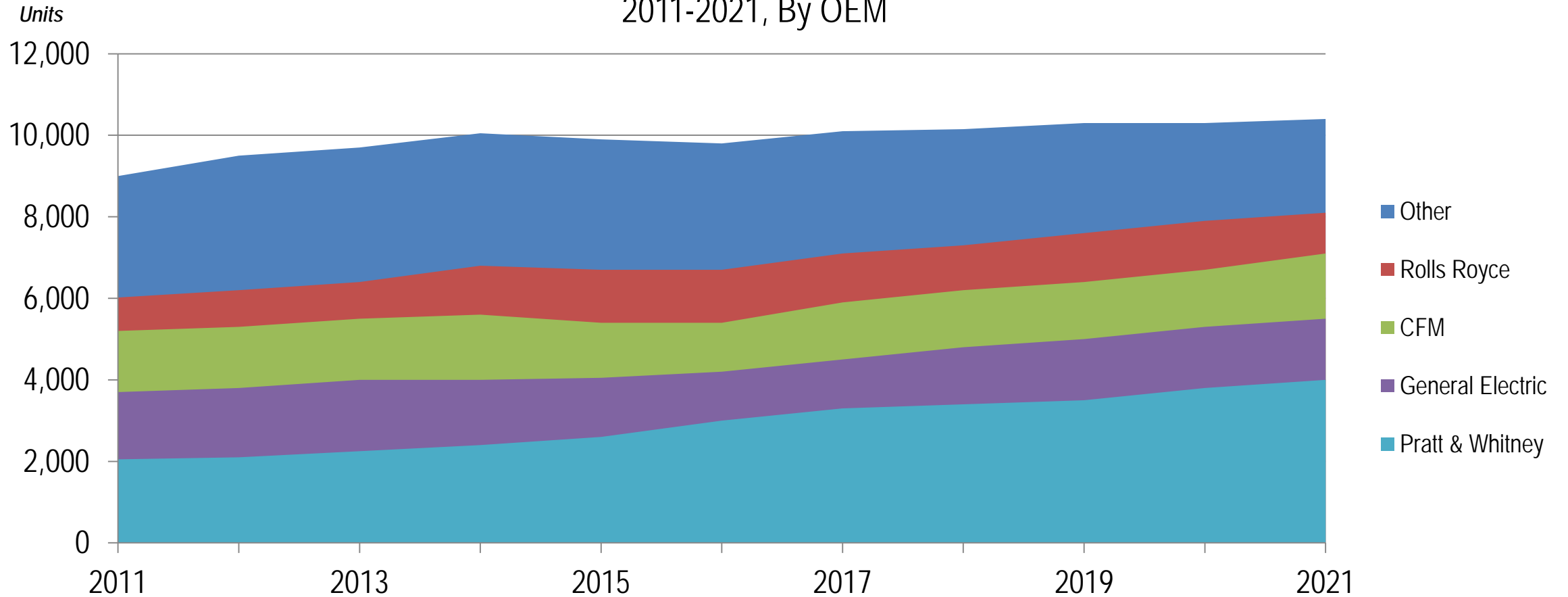

*Includes spares
Source: IFC SH&E

Commercial Engines in Service

History and Forecast

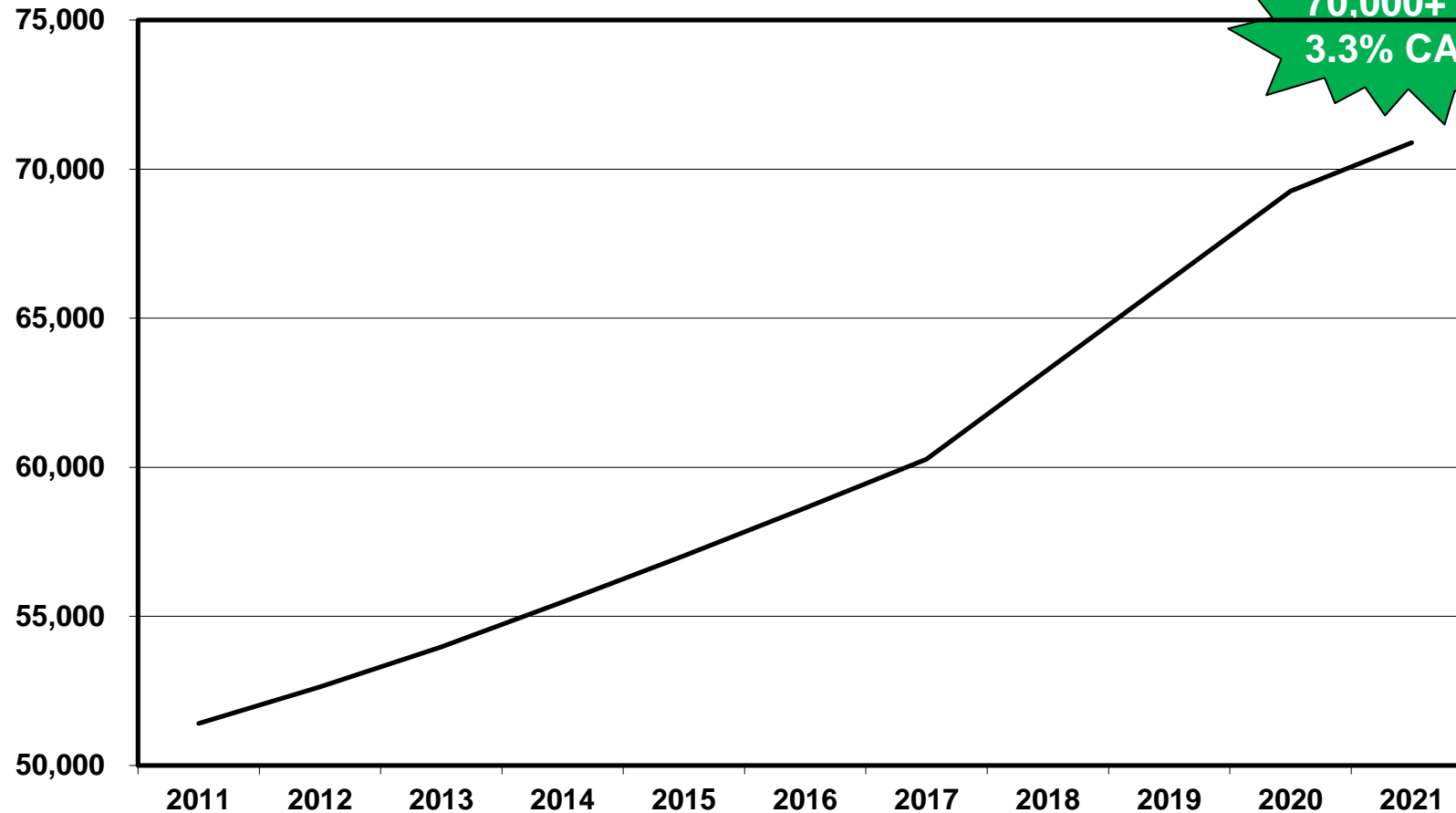

The larger the fleet, the greater the demand for spare parts.

Source: Airline Monitor

Jet Engine Materials

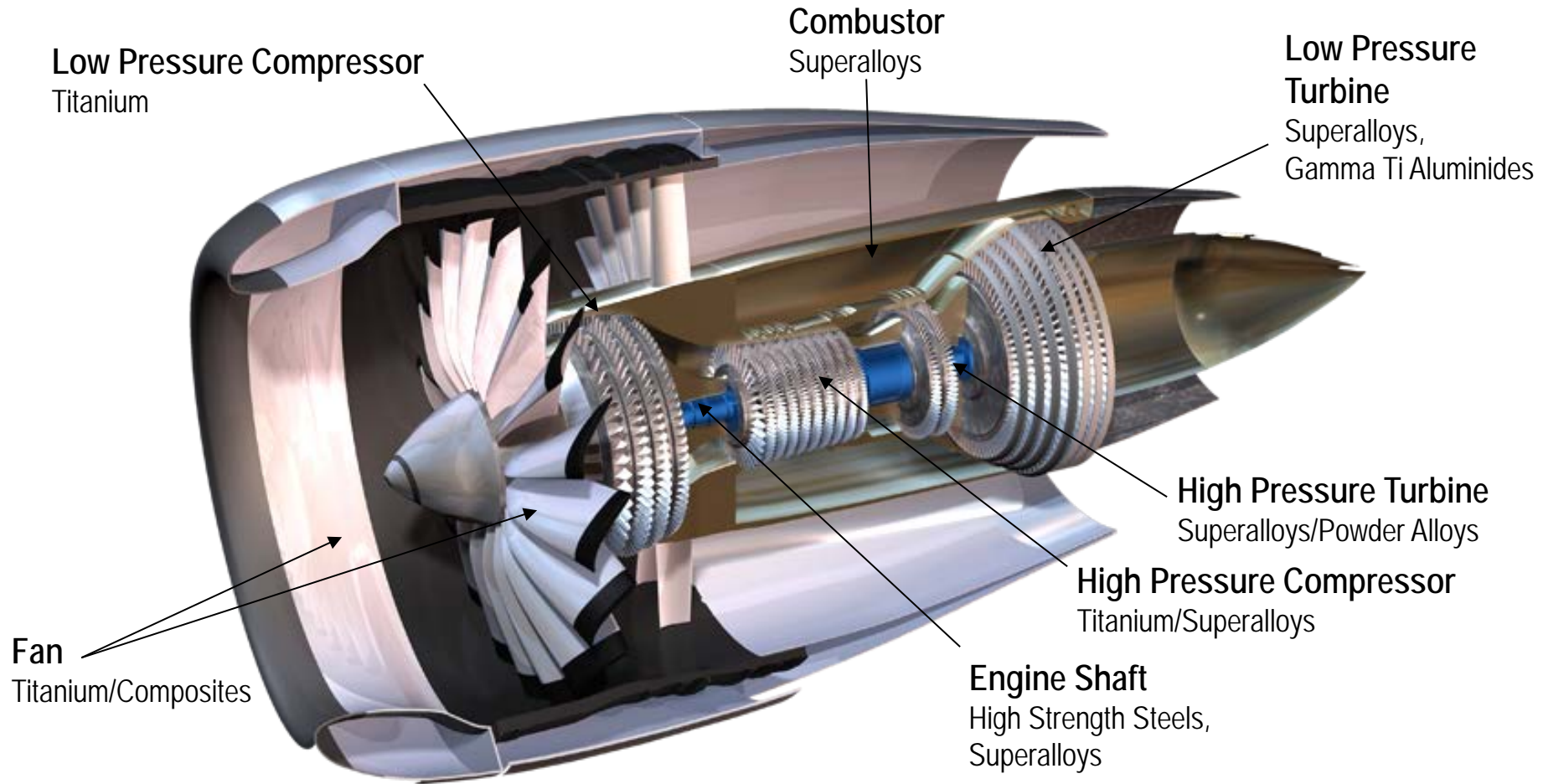

Titanium Applications in Jet Engines

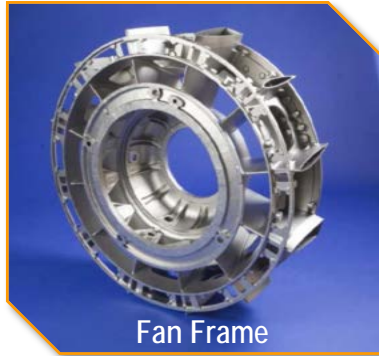

Fan & compressor cases, disks, blisks, impellers, blades, vanes, and fasteners



Titanium & Specialty Alloy Demand Ramping Up with Aeroengine Production

Aerospace Raw Material Demand Forecast

Buy Weight, M lbs.

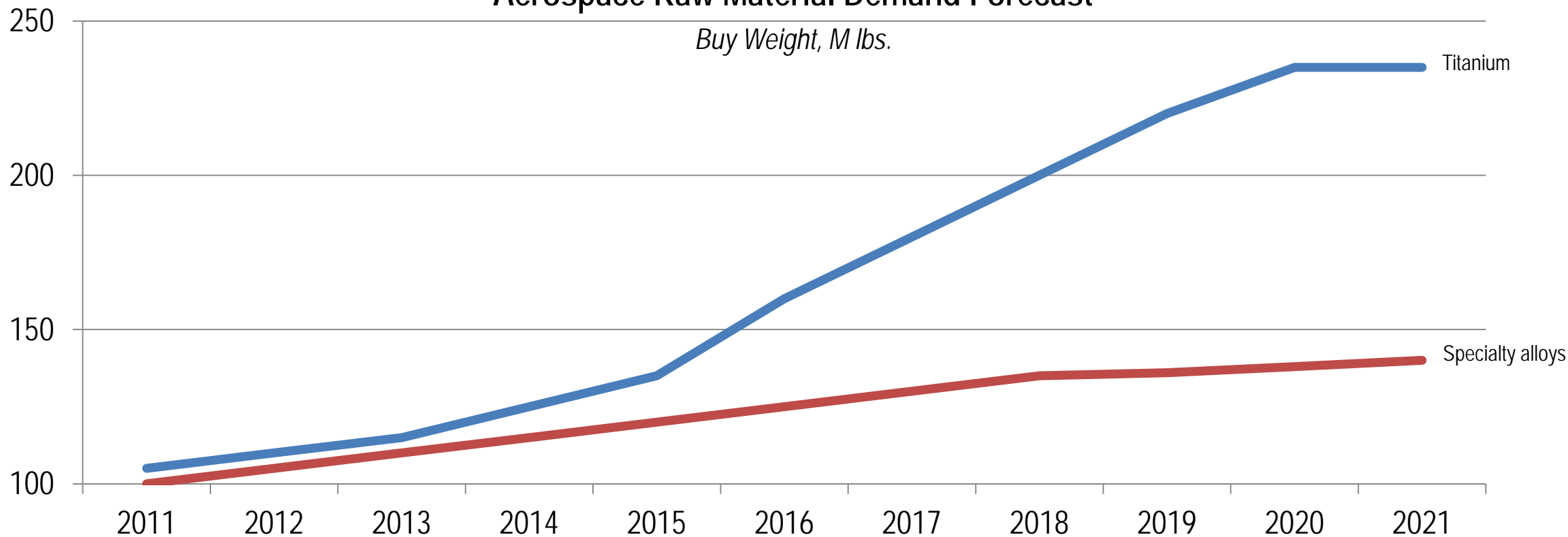

Source: ICF SH&E

- Fundamental drivers & backlogs remain strong.
- Large commercial engines driving titanium demand.

Engine Development Trends

- Demand for “Green” engines
 - Reduced noise
 - Reduced emissions (SO_2 , CO_2 , NO_2)
- Improved fuel efficiency
 - Higher operating temperatures
 - Higher temperature capable materials
 - Lighter materials
- Lower operating costs for airlines
 - Reduced maintenance intervals
 - Reduced part count

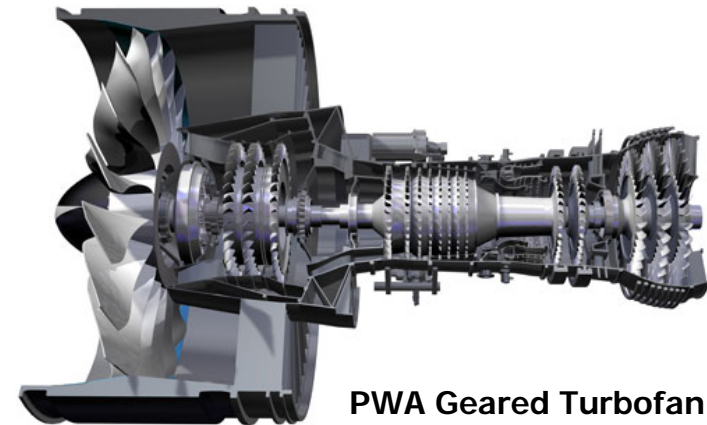

New Designs and Materials

Changes in Jet Engine Design

- Limited introduction of composites
- Larger thrust engines
 - Consume more nickel-based and titanium alloys per engine
- Higher engine temperatures
 - Nickel-based alloy content in compressor growing
 - High temp powder/cast & wrought alloys
- New titanium-based materials
 - Gamma TiAl
- Advanced Manufacturing
- Additive Manufacturing



Evolutionary Change

Commercial Aerospace Panel

15:30 – 16:45 Sala Nettuno

- New titanium-based materials
 - Gamma TiAl – **Dr. Wilfried Smarsly, MTU**
- Advanced Manufacturing – **Mr. Bertrand Flipo, TWI**
- Additive Manufacturing – **Dr. Robert Sharman, GKN**

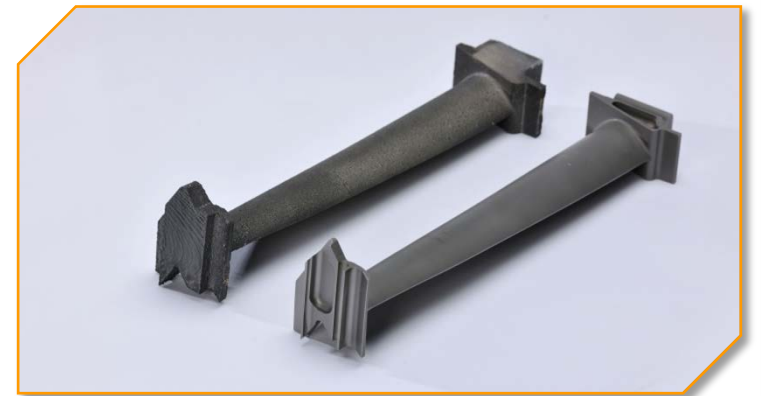

Evolutionary Change

Titanium in Jet Engines

Demand Drivers

- Higher build rates
- Larger engines
- Larger global fleet for spare parts
- New engine designs
- Fuel efficient hotter burning engines

